

**WEIGHT
CAPACITY**
60 Kg

RADIUS
3400 mm

PRESSURE
0.7-0.8 Mpa

VERTICAL LIFT
1700 mm

VERSIONS

COLUMN
FIXED
OVERHEAD
RUNNING
OVERHEAD

Pneumatic Manipulator **POSIVEL PV** with double cable

POSIVEL PV, generally fitted with a hook, can be equipped with simple gripping tools to allow the handling of light loads in a weightless condition in any direction.

The particular double arm structure and medium joint makes it easy to handle and precise throughout the working area.

POSIVEL® - PV22 PV26

Posivel column mounted - PVC

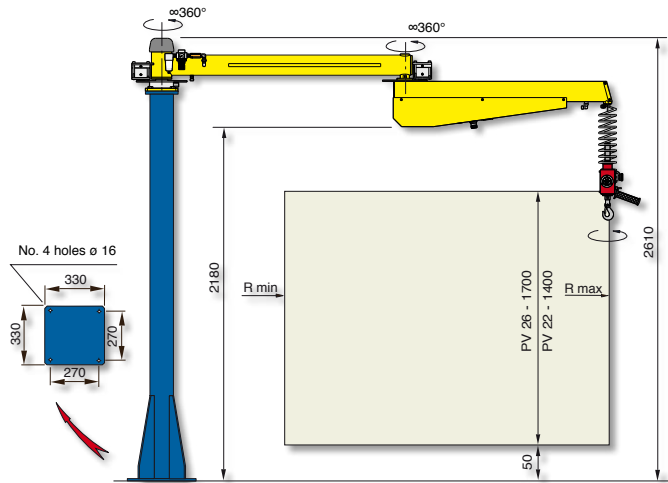

Structural versions: column mounted on fixed base-plate, autostable base-plate of our supply properly dimensioned.

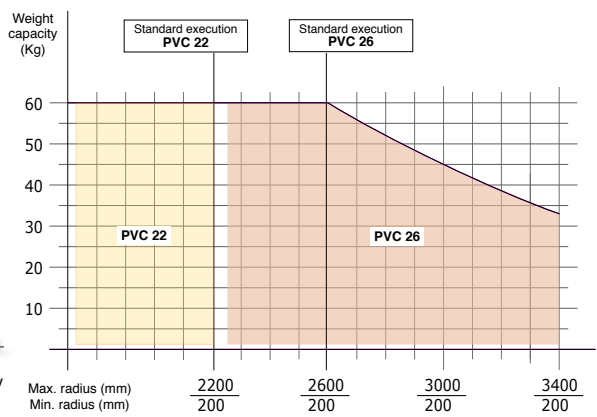

Posivel overhead mounted - PVF

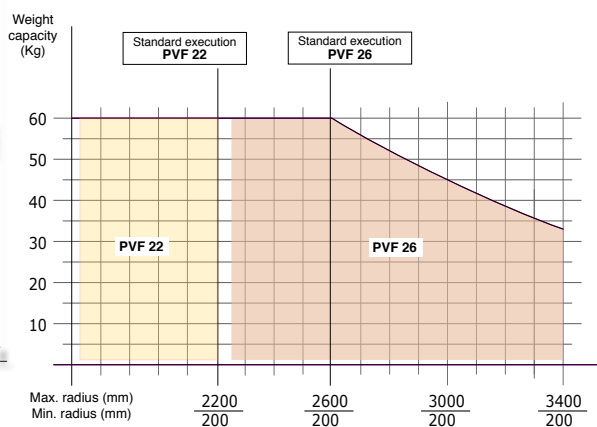
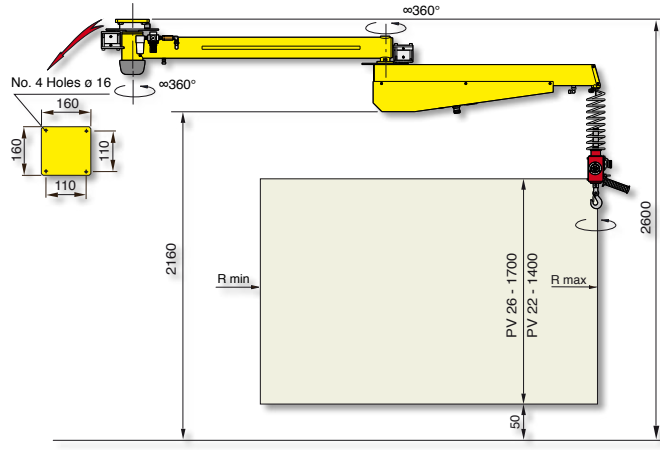

Posivel overhead trolley mounted - PVS

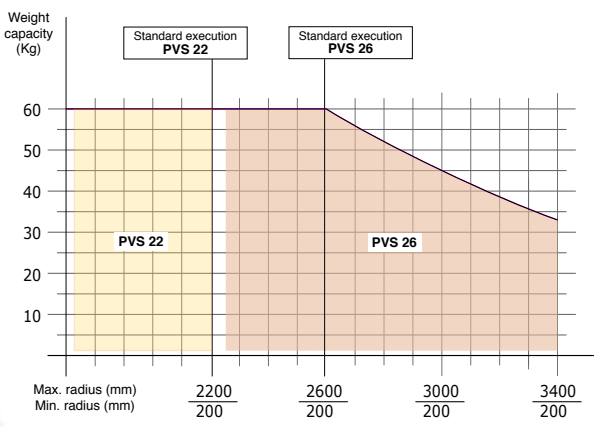
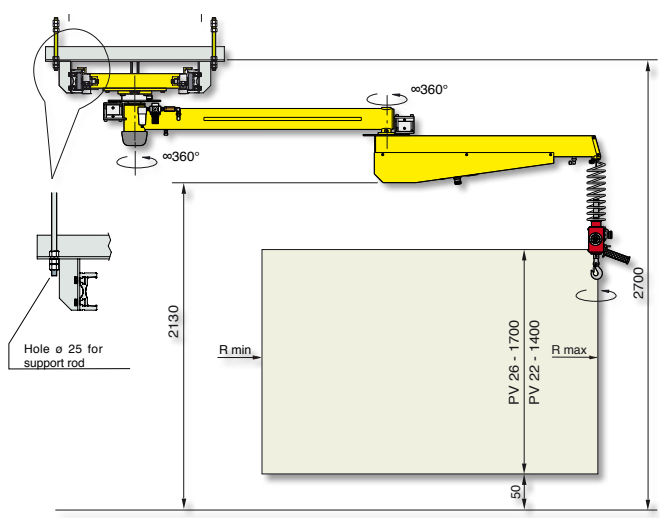

Air supply: Dry and oil-free compressed air min constant 0.7±0.8 MPa

Configuration and measurements may change upon the Customer's specific requirements